

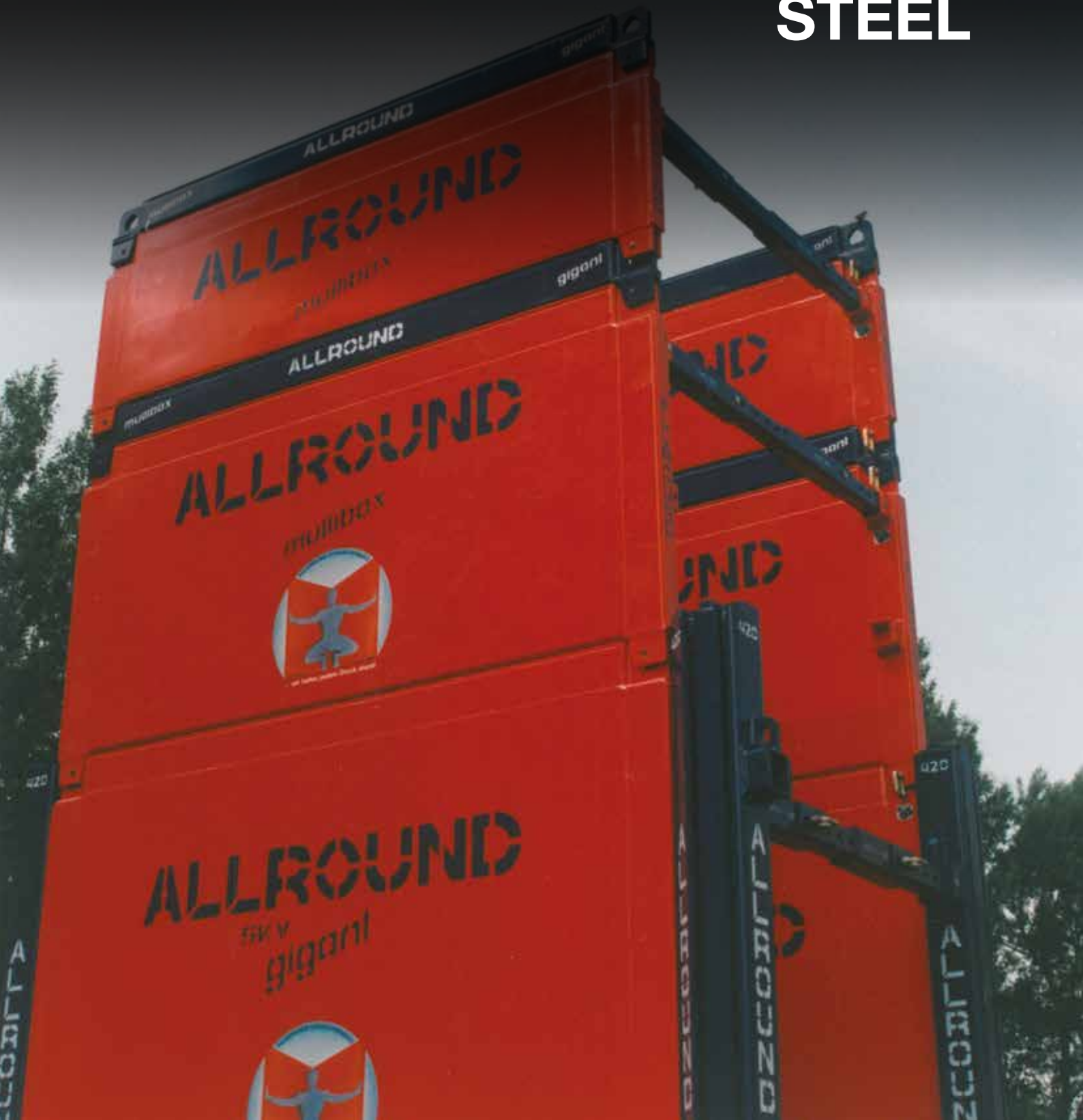

Trench lining systems: **STEEL**



ALLROUND trench lining systems

Simple operation and design is very important to ALLROUND!

Design according to EN standards | Developed according to EN 13331

www.allround.cc

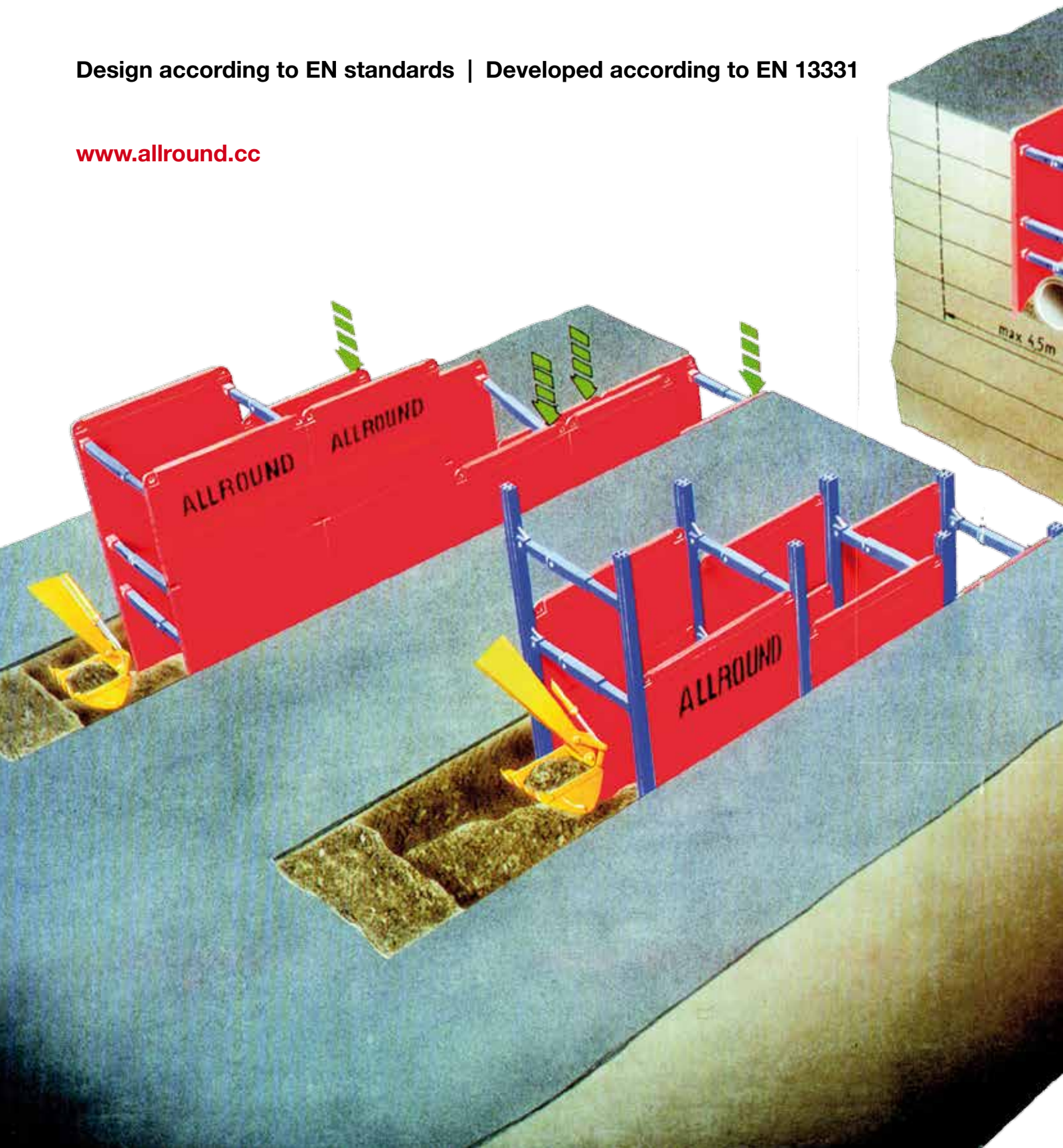

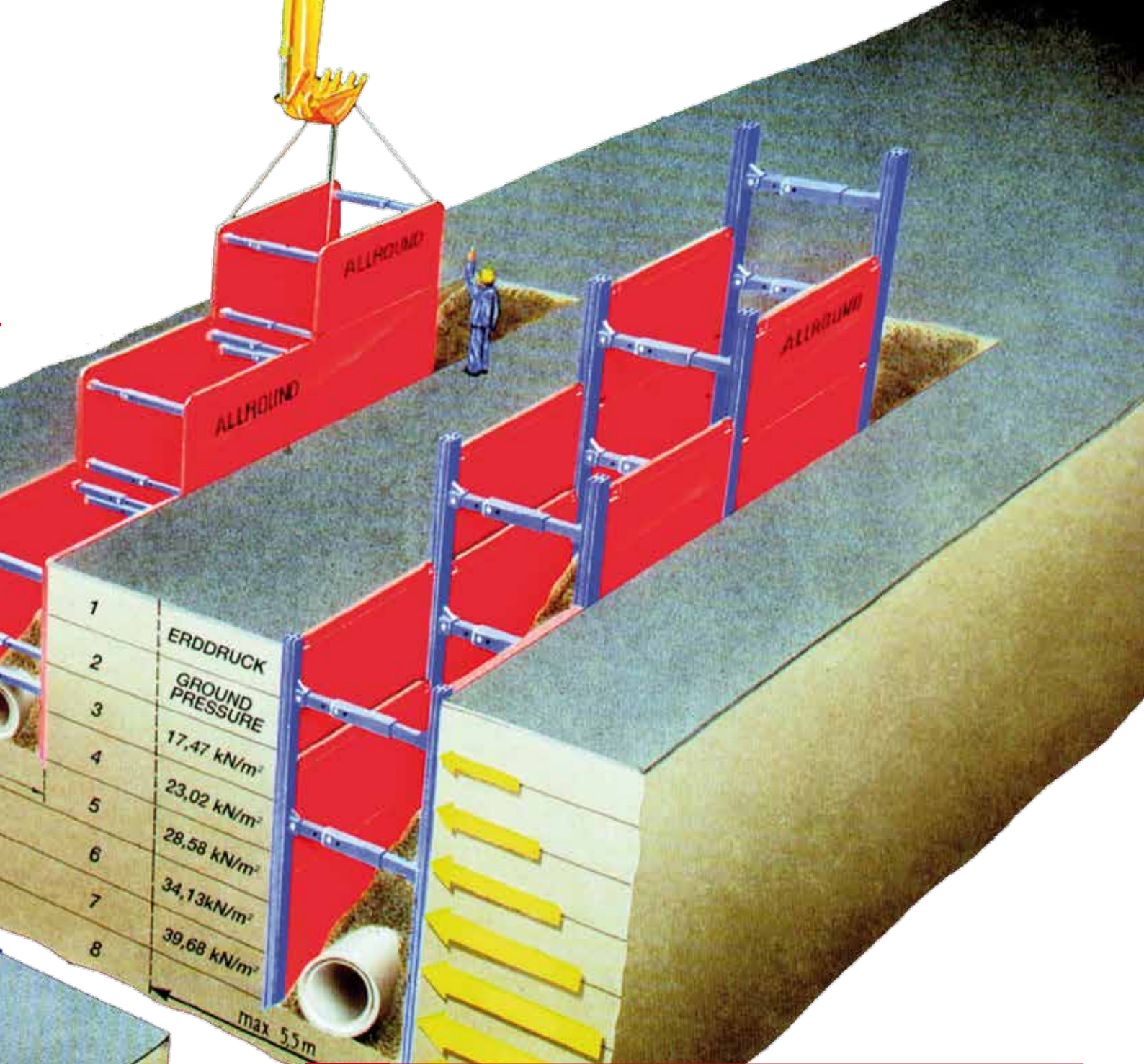

The proven Allround trench lining systems are designed for the **toughest uses**.



The **sophisticated systems** guarantee trouble-free working for many years.



We have dispensed with small parts, threads and even screws to enable the **fastest possible operational readiness** at all times.



Assembly and disassembly of the boxes takes place in minutes – **without any tools!**



Fast, robust and easy handling form the basis for **countless applications**.

BOXES

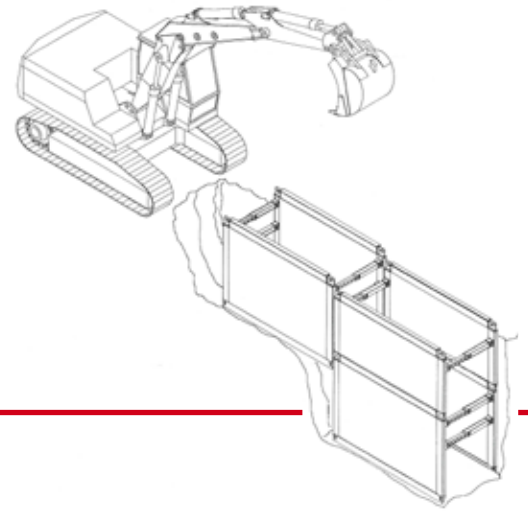

A system with many advantages



UPPER PANEL EDGES

Reinforced by integrated protective rails.

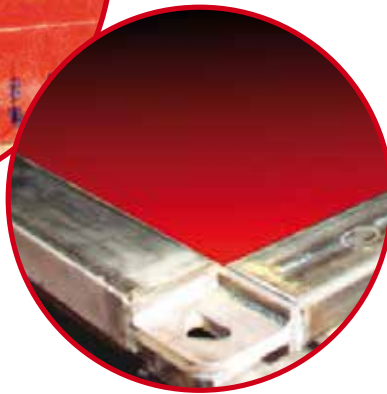

FRAME CONSTRUCTIONS

Extremely stable frame construction due to high steel quality.



A-POSITION STABILITY WITHOUT DEFORMATIONS

Struts of the same length automatically create an A shaped box.



SMOOTH SURFACES

of box panels allow easy excavation and dismantling due to lower static friction and the use of the boxes as external formwork for in-situ concrete.

VARIABLE PASSAGE HEIGHTS

Clearance heights of up to 2.2 metres are possible together with the new adapter rail.

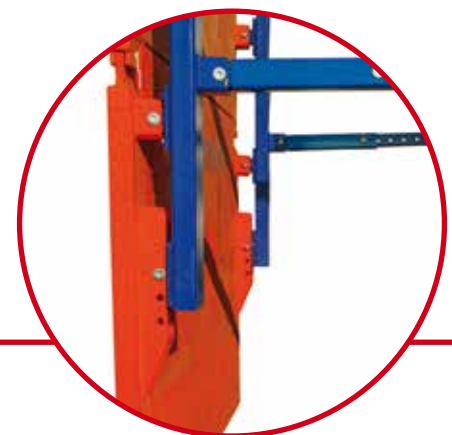

With Allround box systems, you are flexible, with storage and transport being as simple as you like. The boxes do not have to be transported or stored pre-assembled in a space-consuming manner, and you don't have to waste time and money during assembly or disassembly.

While others may still be busy with assembly, you can already start with the actual work of building the sewer pipe line.

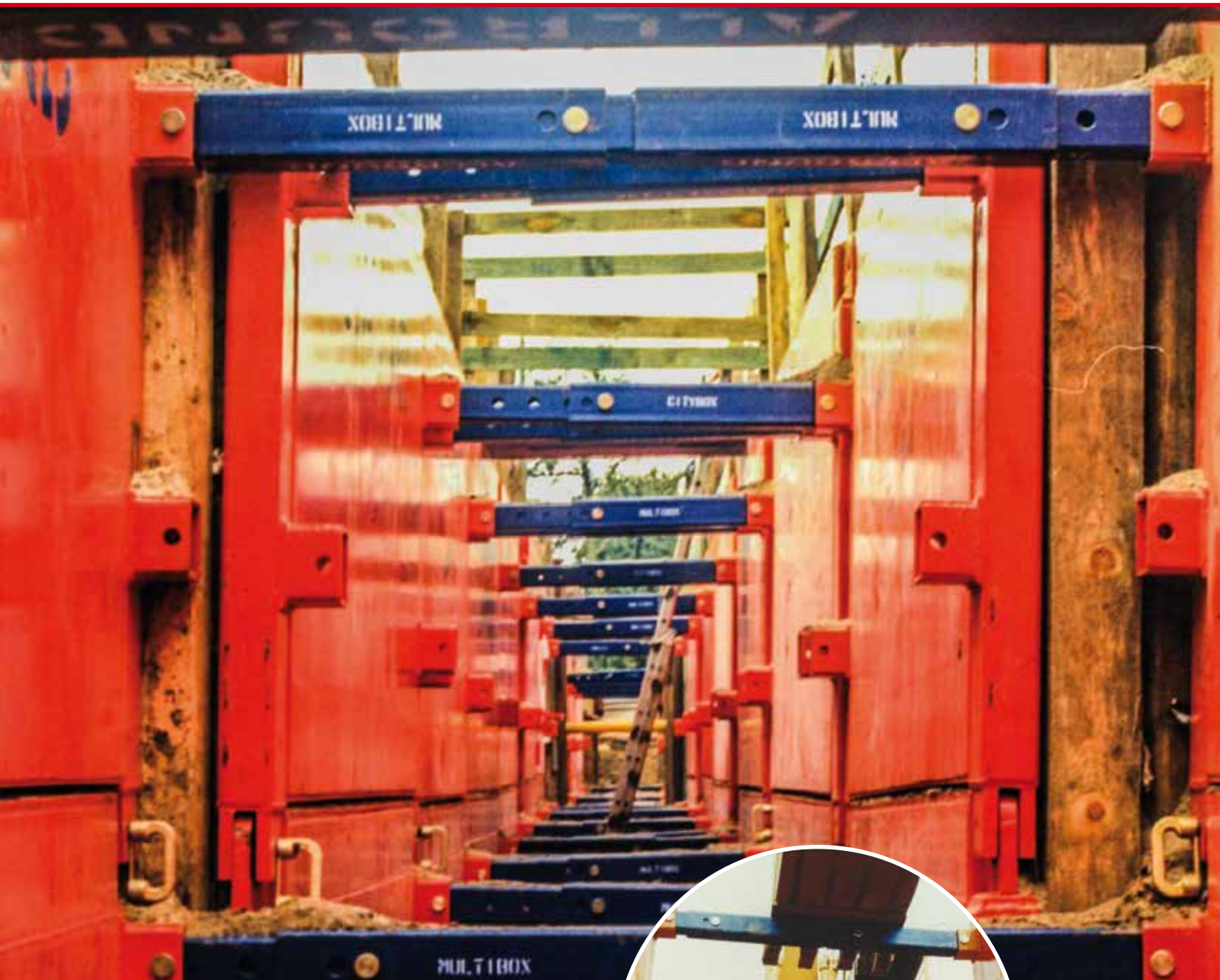

TELESCOPIC RECTANGULAR STRUTS

For the desired setting of the required trench widths. The square design and the few parts increase the durability.

MOBILE CUTTING EDGES AND ADAPTER RAILS

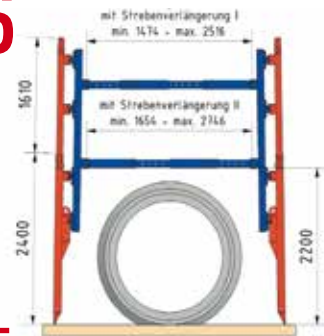

The really useful inventions for ALLROUND box systems

MOBILE CUTTING EDGE FOR CONVERSION FROM EXTENSION BOXES TO TRENCH BOXES

The ever popular MOBILE CUTTING EDGE offers considerable possibilities for cost reduction. With this easy-to-fit extension, the conventional ALLROUND extension boxes can be converted into basic boxes in no time at all and used for direct sinking into the ground. At a fraction of the acquisition cost of new basic boxes, the range of applications of already purchased trench lining systems can be extended many times over.

Of course, the same mobile cutting edges can also be used for the extension panels in ALLROUND slide rail trench lining.



ADAPTOR RAILS ALLOW A PASSAGE HEIGHT OF 2.2 METRES

Sewer pipes with a diameter of 2 metres can now be laid with ALLROUND trench boxes. The newly developed MULTI adapter rail offers the possibility of extending a MULTI box together with an extension box to a passage height of 220 cm. An great extension for all those who need a higher clearance in trench lining.

ALLROUND's way of doing things can also be see here: Existing systems can continue to be used and can be upgraded with low acquisition costs and for higher requirements.



MANHOLE BOX SHORING

A system for fast shaft construction

MANHOLE SHAFT BOX SYSTEMS

The ALLROUND manhole shaft box systems have been developed to offer a market-leading strength to weight ratio. The lightweight manhole box is specially designed for small to medium excavators with limited lifting capacity. The standard shaft box series is designed for excavators with more than 16 tons.

They enable the installation of pipes with a diameter of up to 1.4 m and are suitable for trench depths of up to 5.6 m.

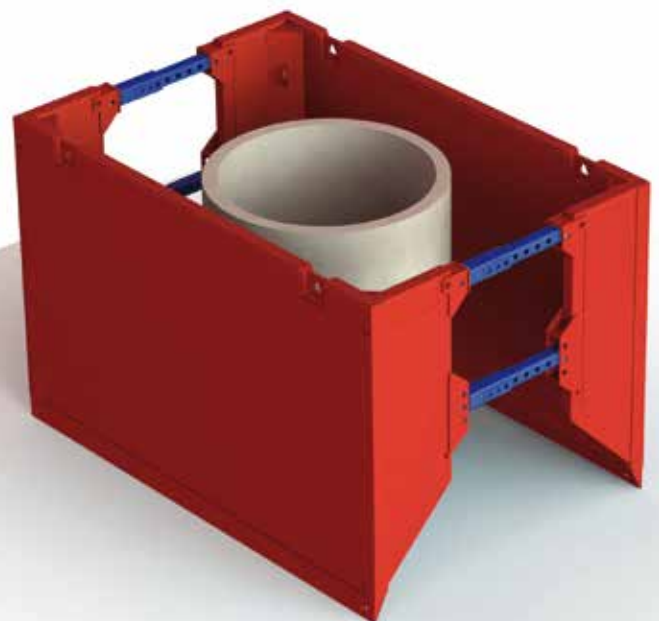

GIGANT DOUBLE SLIDE RAILS SHORING SYSTEM

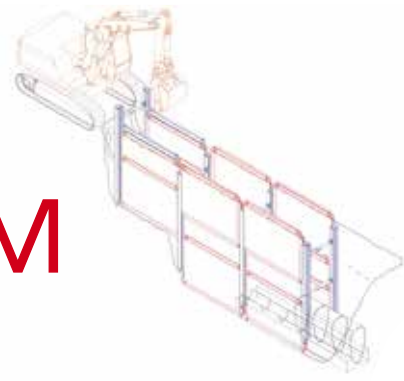

A system with many possible uses



CONTINUOUS PANEL GUIDANCE
For improved earth pressure absorption.



SWIVELLING PANELS
In guides to reduce and increase the trench width and to reach radii.



DRAINAGE EFFECT
The continuous round guides ensure that the trench lining is almost watertight when there is groundwater in the guides.



SMOOTH INNER SURFACES
The trench lining panels allow easy excavation and dismantling due to lower static friction and the use of the panels as external formwork for in-situ concrete.

VARIABLE LINING WIDTHS
Simple, pluggable square struts also allow large distances between the trench lining panels.



The upper edges of the panels are very robust and the rails have been equipped with integrated protective rails. This means that even difficult jobs will not necessarily be followed by high repair costs. ALLROUND box systems are compatible with sliding trench lining.

Clear lines and the absence of annoying screw connections ensure easy handling.



CAN BE COMBINED WITH THE MULTIPLE EXTENSION PANELS

DOUBLE SLIDE RAILS WITH INTEGRATED REINFORCEMENT CAP

For trench depths up to 8 m



GIGANT CORNER SLIDE RAIL SYSTEM

A system with many advantages



USABILITY & COMPATIBILITY

As with all ALLROUND products, the focus in this further development was on practical usability combined with maximum compatibility. For example, all GIGANT slide panels used in trench lining fit into the new corner rails.

ALLROUND customers can therefore also use elements already in use in trench lining for shaft lining.



PROVEN & SIMPLE

You only need the angle rail – designed as a double slide rail – to be able to use an existing ALLROUND GIGANT double slide rail lining as shaft lining. All other parts are fully compatible. The angle rail is extremely robust and, as usual with Allround trench lining, does not require screws, nuts, rollers or other small parts. Maintenance costs are thus reduced to a minimum and assembly of the trench lining at the place of use is simple, easy and quick.

Different panel lengths are available so that all conventional shaft types can be manufactured. The flexible use of the existing slide panels helps to keep the acquisition costs for the new system low. Of course we have kept our usual robust construction (reinforced frame, reinforcement cap integrated in angle rail) and high-quality workmanship (welded seams).

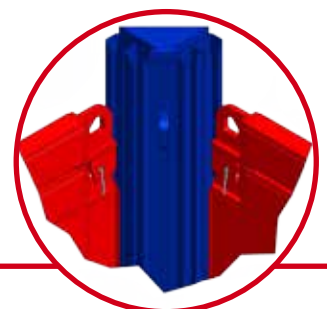
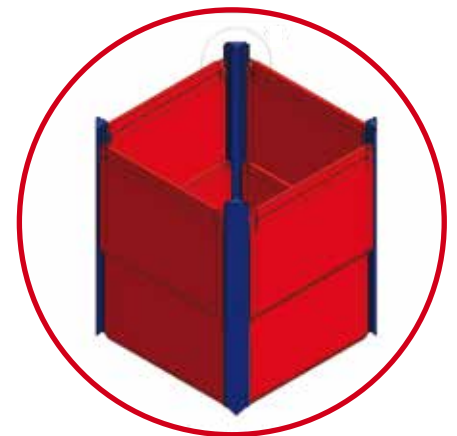

The proven and widely used trench lining system from ALLROUND is in successful use in 18 European countries and in Africa. The ALLROUND GIGANT shaft lining system was developed following the same high-quality, robust and easy-to-use principle as the trench lining system.

The shaft lining system has already proven its qualities in practical use and is compatible with the proven GIGANT slide rail lining system.



THE NEW CORNER RAILS

can be easily combined with all existing slide panels, slide rails and multiple extension panels.



Trench lining systems:
STEEL



Trench lining systems:
ALUMINIUM

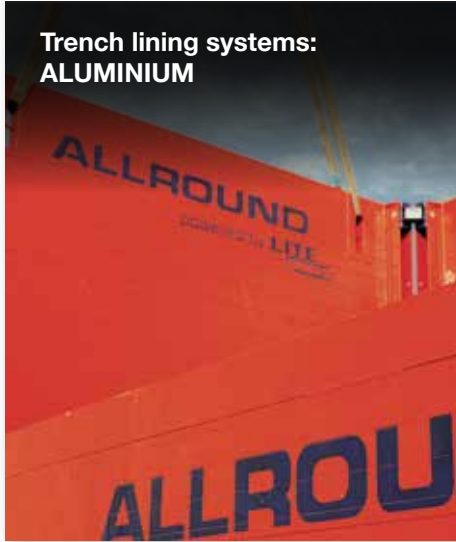

Trench lining systems:
NON METALLIC



ALLROUND SYSTEMS – DESIGNED FOR TASKS UNDER PRESSURE

There are different ways to reach your goal. ALLROUND has never been interested in established paths and has always endeavoured to find new technical solutions in the interests of its customers. ALLROUND has incorporated many suggestions from numerous users worldwide into the design of our 3rd generation of trench linings. Practical experience has produced our trench lining systems, which are just what you need. Our philosophy has made us the market leader in Austria, and we would like to thank our customers for this.



**ALLROUND a product from
AM Baugeräte HandelsgmbH**

Oberes Bahnhof 2
A-2281 Raasdorf
Phone (+43 2249) 28495
office@allround.cc
www.allround.cc



Hirnböck Stabau GmbH

Our distribution partner in:
West Austria
Southern Germany
Switzerland
Albania
Israel

Phone (+43 662) 450613
office@spundbohle.at
www.spundbohle.at